

Generator Start Control Module

Part# GSCM-mini-o

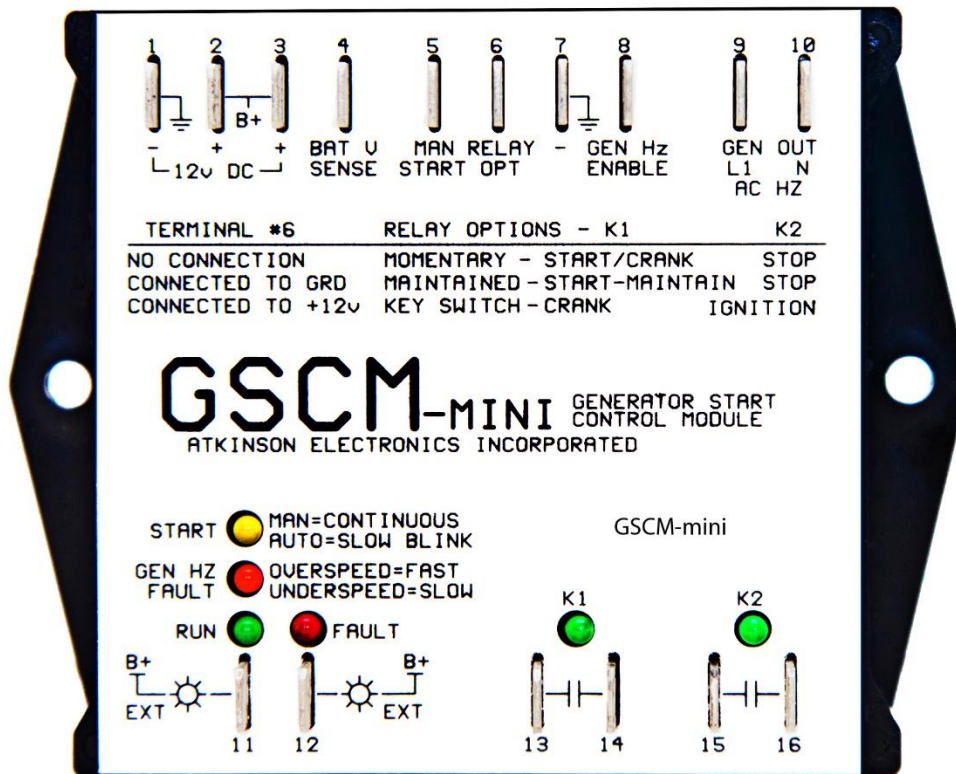

ATKINSON ELECTRONICS, INC.

14 West Vine Street · Murray, Utah 84107

Contact cbdsales@atkinsonel.com for the proper hookup diagram. Please include the generator make & model, inverter brand, & battery bank voltage.

Table of Contents

Modes of Relay Operations	3
LED Indication Description	3
Operational Thresholds	3
Typical Wiring Diagram	4
Option 1 Diagram	5
Option 2 Diagram	5
Option 3 Diagram	5
Option 1 Starting Sequence	6
Option 2 Starting Sequence	7
Option 3 Starting Sequence	8
Manual Off Auto Switch Options	9
Fault Shutdown Conditions	9
Automatic Starting for Battery Charging	10
Generator Emergency Shutdown	10
LED Description and Meanings	11
Specifications	11
Remote RV Generator Start Drawing	12
Outback Inverter/Inverter Style Drawing	13
Outback Inverter/Honda EUxxOOis Drawing	14
Samlex America EVO Inverter Drawing	15
Limited Warranty	16



Included
Pilot Lamp Feed Back Cable
A0397

Features & Applications

- Inexpensive 2 wire to 3 or 4 wire start controller for electric start 3 or 4 wire gas generators
- Optimized for use with Outback Invertors
- Supports three types of 3 or 4 wire generator control: Momentary, Maintained & Ignition
- Fixed crank time, over and under Hz shutdown, and optional battery charging thresholds
- Maximum auto-start run time limit (6 hours)
- Remote run and fault indication included
- ABS epoxy sealed for harsh environment operation

Solving your generators 2 to 3 or 4 wire start-stop problem.

Description

The GSCM-mini-o is a micro-processor based generator start-stop module, designed to auto start-stop generators that need a 3 or 4 wire connection from a 2 wire 12 volt or dry contact manual start command. The GSCM-mini-o automatically disconnects the starter when it either receives a remote start indication lamp signal (*connected to terminal 8*) or an AC Hz signal from the generator (*AC connected to terminals 9 & 10*). Various LEDs are blinked or turned on to indicate the run or fault status of the GSCM-mini-o. Manually resetting the GSCM-mini-o by removing the power and removes any lockout that allows the generator to restart if called to do so.

The GSCM-mini-o is powered by 12VDC from the generator battery and can monitor the battery voltage and start the generator to charge its own battery if connected to pin 4. The GSCM-mini-o is a limited function controller that is part of the GSCM family.

All auto start battery voltage thresholds are fixed, if adjustability is required use the GSCM full function Generator Start Control Module.



Three Modes of Relay Operation

There are 3 different options for the GSCM-mini-o's two relay contacts to be configured: **Momentary**, **Maintained and Ignition**.

This is accomplished with an optional jumper on terminal 6.

Momentary Start Contact Option #1: *Terminal 6 has no connection.* The GSCM-mini defaults to a momentary crank operation for those generators that use two momentary push button switches to start and stop the generator. K1 cranks the Starter. On shutdown, K2 momentarily grounds the magneto. See option 1 for operation description.

Maintained Start Contact Option #2: *Terminal 6 is grounded.* The GSCM-mini changes to a maintained start operation for generators that use a maintained closed contact to start (K1). The generator is stopped by opening K1 and closing K2 contact, momentarily grounding the magneto. See option 2 for operation description.

Ignition Key Switch Start Contact Option #3: *Terminal 6 is connected to B+ (12VDC).* The GSCM-mini simulates an automobile ignition switch, K2 closes, maintains a closed ignition contact for the generator to run and K1 closes momentarily to crank the starter motor and de-energizes when the start signal is removed. The K1 relay operates in a momentary crank configuration. See option 3 for operation description.

If adjustability is required then refer to the GSCM full function control module.

LED Indication Description

The GSCM-mini-o has six indication LEDs.

The Start LED blinks once every 5 seconds to indicate it is ready for a start signal. The LED will blink once every 2.5 seconds to indicate its running in auto start mode. On continuously indicates running in manual start mode.

The Generator Hz LED blinks to indicate over/under Hz fault and start failure due to maximum crank attempted. A slow blink indicates an under Hz condition while a fast blink indicates an over Hz condition if pin 8 is grounded. On continuously indicates AC present in a non-run condition. A double blink indicates a start failure condition. Four blinks indicates generator shut down due to its own fault condition or lack of fuel.

The Run LED, On continuously indicates a valid run signal from the generator.

The Fault LED, On indicates a fault condition has occurred and GSCM-mini is in lockout and must be reset.

The K1 and K2 LEDs indicate the relay status.

Operational Thresholds

GSCM-mini-o fixed operational thresholds:

Crank delay:	5 seconds
Maximum crank:	30 seconds
AC crank disconnect:	45Hz
DC crank disconnect:	Voltage greater than 9VDC
Under speed shutdown:	55Hz
Over speed shutdown:	65Hz
Max auto start run time:	6 Hours
Manual start run time:	Indefinitely
Auto start/stop thresholds:	<u>Start</u> <u>Stop</u>
12V system	11.5V 13.8V standard
24V system	23.0V 27.6V auto selects
48V system	46.0V 55.2V auto selects
Relay configuration:	Open input = momentary crank
(Terminal 6)	Grounded input = maintained crank
	B+ (12VDC) input = ignition & crank

Fault detection:

- Start failure (3 attempts)
- Generator stops due to its own fault condition

Fault detection if pin 8 is grounded:

- Over Hz condition (10 seconds)
- Under Hz condition (10 seconds)



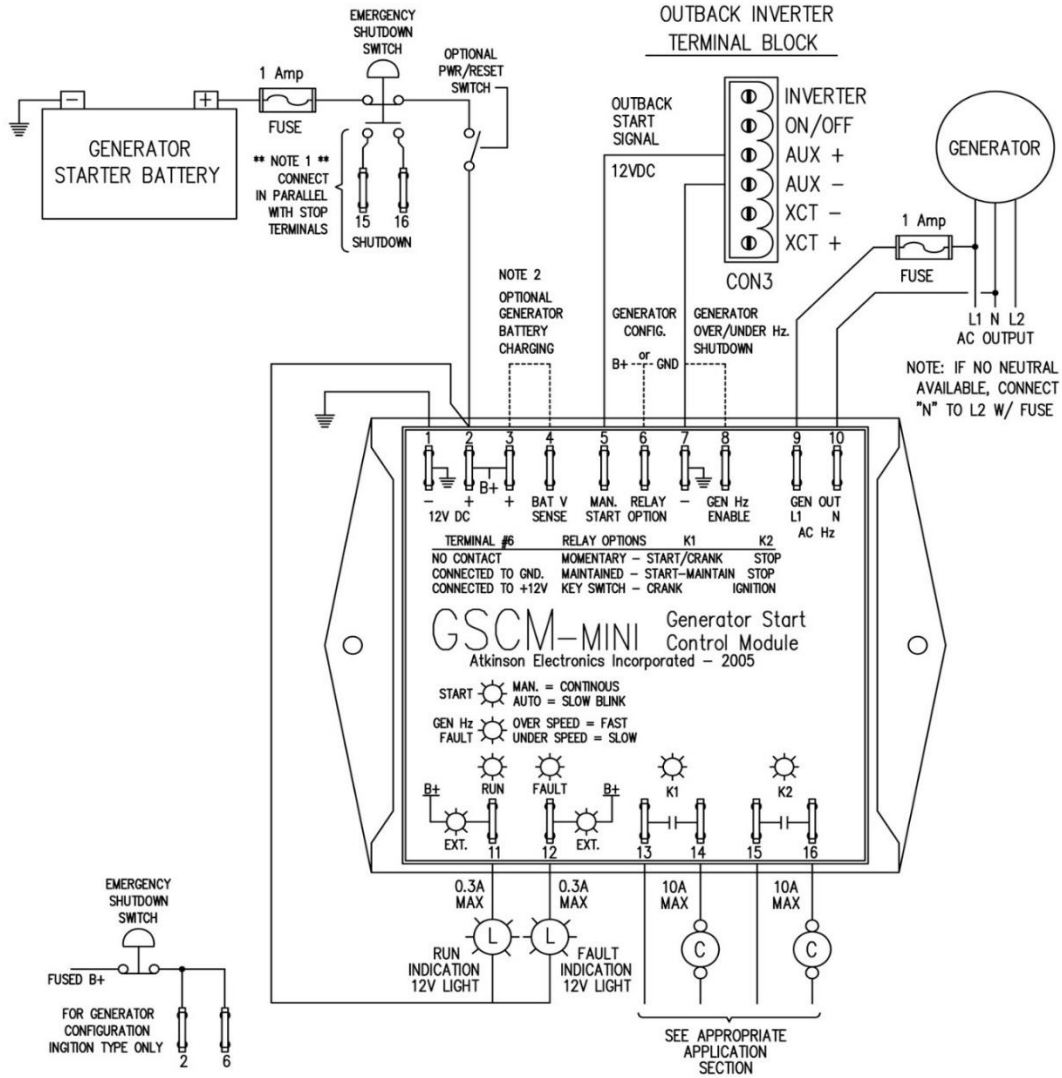

NOTE 1
IF THE GENERATOR THREE (3) WIRE START/STOP CONNECTION REQUIRES AN IGNITION (MAINTAINED CONTACT CLOSER TO RUN) AND A CRANK CONTACT TO START THE GENERATOR, THE EMERGENCY SHUTDOWN SWITCH ONLY NEEDS A SINGLE CONTACT TO DISCONNECT THE POWER FROM THE GSSM. REMOVING POWER CAUSES THE STOP/IGN RELAY TO DE-ENERGIZE SHUTTING DOWN THE GENERATOR. See Page 6 Section 6

NOTE 2
THE BATTERY VOLTAGE SENSE INPUT IS USED TO PROVIDE AN AUTO START FOR THE GENERATOR TO CHARGE ITS OWN CRANK BATTERY. THE OUTBACK INVERTER ALREADY MONITORS ITS OWN BATTERY BANK AND PROVIDES A START SIGNAL TO THE GSSM TO START THE GENERATOR TO CHARGE 12V, 24, OR 48V BATTERY BANKS.

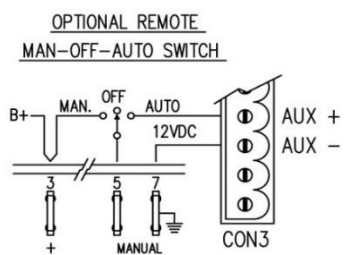

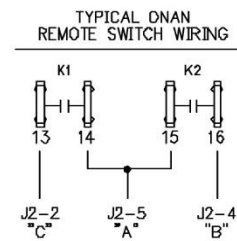
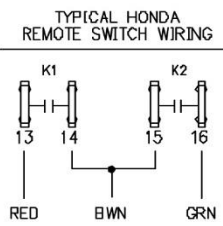
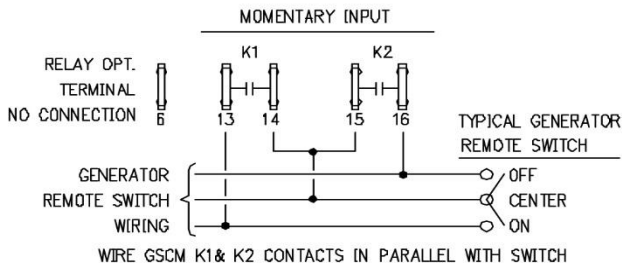

The GSCM-mini-o option 1 provides the momentary contact closer to start or stop the generator as if the start/stop switch had been pressed by the user. When the GSCM-mini receives a start command signal or the battery voltage drops below the start threshold it energizes K1 relay, providing a signal to the start/crank input and removes it when the generator has reached 45Hz, or half speed. The K2 relay also provides a momentary stop signal until the generator AC Hz has dropped to zero. For operational sequence details see page 6, option 1.

Option 2 Maintained Start Contact

Typical Generator with Starter Control Box

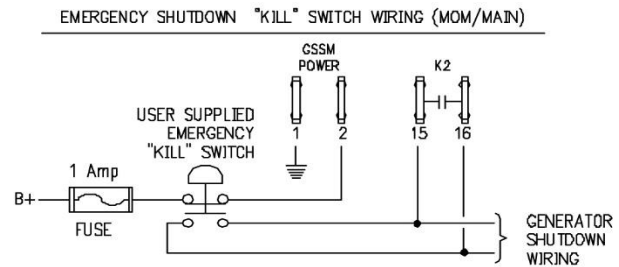
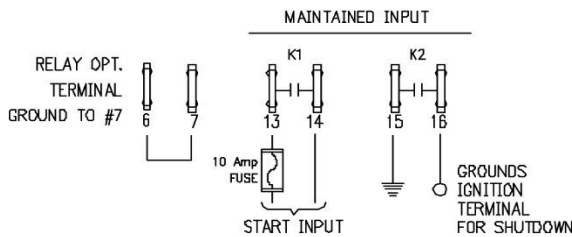

The K1 relay provides a continuous run signal for generators requiring a maintained start signal. The K2 relay provides a momentary stop signal until the generator AC Hz has dropped to zero. For GSCM-mini operational sequence details see page 7, option 2.

A double pole kill switch wired and installed by the user, stops the generator instantly in emergency situations such as a fuel spill. One switch pole (N.C.) kills power to the GSCM-mini opening all relays. The other switch pole (N.O.) shorts out the magneto for an instant stop.

Option 3 Ignition Key Switch Type Start Contact

Typical Generator with Starter Control

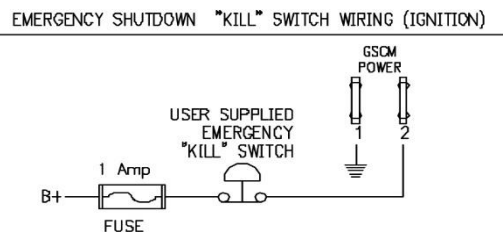
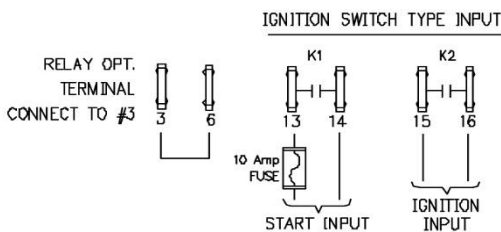

The K1 relay is used to switch the starter input that is looking for a momentary signal and opens it when the AC line output has reached 45Hz. The K2 relay provides a continuous run signal for generators requiring a maintained ignition signal. When the GSCM-mini no longer receives a run command, K2 relay opens telling the generator to shut down. For GSCM-mini operational sequence details see page 8, option 3. A single pole kill switch wired and installed by the user, stops the generator instantly in emergency situations such as a fuel spill. One switch pole (N.C.) kills power to the GSCM-mini opening all relays shutting down the ignition switch type generators.



The GSCM-mini-o accepts Outback's 2 wire switched 12VDC start /run signal or a dry contact, like Samlex, Trace and others, to produce a 3 or 4 wire start/stop signal for most gas and propane generators. Using the generator's remote port and remote pilot lamp (PL) signal, if available, can make for a quick and easy installation. Some inverter style generators, like Onan and Honda, do not produce an AC output until the generator is up to full speed which may cause the GSCM to over crank the starter. Using the PL signal eliminates this issue. The PL signal or 120/240VAC provides feedback telling the GSCM when to stop cranking the starter and when the generator has completely shut down. A red connector with a protection diode is provided to connect between terminal 8 on the GSCM-mini and pilot lamp wire for applications where the pilot lamp signal is positive or high. If the pilot lamp signal is negative or goes low the pilot lamp signal inverter must be used. The generator's combination switch should be left in the remote position for the GSCM-mini to auto start the generator. The starting sequence is as follows:

1. The start LED blinks once every 5 seconds to indicate that the GSCM-mini is in a ready mode. When a manual signal is received, the start LED lights continuously. After a 2 second delay, the K1 relay closes to crank the starter and remains closed until either the generator starts or the maximum cranking time period of 30 seconds is reached.
2. If the generator fails to start during the 30 seconds cranking period, the K1 relay opens for a resting period of 40 seconds. At the end of the period, the K1 relay then closes again, cranking the starter until the maximum cranking time is reached or the generator starts.
3. If the generator fails to start after 3 cranking attempts with the associated resting periods, the K2 relay then closes for 5 seconds to ensure the generator is not running, the Generator Hz LED does a double blink, the fault LED turns on and the GSCM-mini enters the maximum crank lockout fault condition. This lockout condition remains until the GSCM-mini is reset by removing power from terminal 2, waiting 5 seconds and then reconnecting power (see GSCM-mini wiring diagram, page 4). This clears the lockout condition, and the GSCM-mini re-enters ready mode with the start LED blinking every 5 seconds.
4. When the generator starts, the K1 relay immediately opens, stopping the cranking. A valid run condition is determined by one of two conditions: A 12V run status pilot light signal provided by the generator connected to terminal 8, or by the generator's AC output frequency exceeding the crank disconnect setting of 45Hz (terminals 9 & 10). The GSCM-mini indicates that it has received either signal by turning on the run LED.
5. If the generator starts but shuts down after a few seconds due to a fuel problem, etc., the start sequence will revert to the ready mode after a 60 second delay. During this delay the start LED will blink rapidly. The GSCM-mini will then try to start the generator again in manual mode or after a 5 minute delay period in auto-start mode.
6. When a run condition is detected, the GSCM-mini turns on the run LED and transistor output (remote run lamp terminal 11). If an AC signal was detected to disconnect the starter, the GSCM-mini will begin a 60 second generator stabilization period before it begins monitoring the AC Hz signal for over/under Hz condition, if enabled (terminal 8 is grounded).
7. If the generator starts but shuts down after the 60 seconds stabilization period, due to a fuel problem, low oil pressure, broken AC Hz or 12V run status wire, the GSCM-mini blinks the generator Hz LED for an under Hz condition, after 60 seconds the run LED turns off, K2 relay energizes for 5 seconds, and fault LED turns on and the generator Hz LED blinks four times every two seconds. The GSCM-mini enters a fault shutdown lockout condition and must be powered down to reset the fault lockout.
8. If no faults occur, the generator will continue to run until one of the following occurs: The manual start signal is no longer received and the auto battery charge voltage or maximum auto run time has been reached, while running in auto charge mode over Hz condition, under Hz condition occurs if the generator over/under Hz shutdown is enabled, or the generator runs out of gas.



9. During shutdown, K2 relay closes to ensure the shutdown of the generator by grounding out the ignition, etc. It remains closed until the AC Hz signal from the generator has gone to zero for 5 seconds to ensure that the generator has shutdown.
10. The generator remains off until another start signal is received.

GSCM-mini-o Relay Option 2

Maintained Starting Sequence

The configuration terminal 6, has been connected to ground (terminal 7) which configures the GSCM-mini-o for maintained start sequence. The GSCM-mini is then powered by connecting B+ (12.0 VDC) to terminal 2. The Start LED turns on for 5 seconds while the GSCM-mini initializes with option #2 maintained starting sequence then begins blinking the start LED once every 5 seconds. The generator starting sequence is as follows.

1. The start LED blinks once every 5 seconds to indicate that the GSCM-mini is in a ready mode. When a manual start signal is received, the start LED lights continuously. After a 2 second delay, K1 relay closes to start the generator. The K1 relay remains closed until either the start signal is removed or the maximum cranking time of 1 minute is reached.
2. If the generator fails to start after a single 1 minute start period, GSCM-mini runs thru its Shutdown Routine, the Fault LED turns on and the GSCM-mini enters the Maximum crank lockout condition and the Generator Hz LED does a double blink. This lockout condition remains until the GSCM-mini is reset by removing power from terminal 2 (see GSCM-mini wiring diagram page 4), waiting 5 seconds and reconnecting power. This clears the lockout condition, and returns to ready mode.
3. When the generator starts, K1 relay remains energized. A valid run condition is determined by one of two conditions: a 12V run status pilot light signal provided by the generator connected to terminal 8, or by the generators AC output frequency exceeding the crank disconnect setting of 45Hz (terminals 9 & 10) and is indicated by the run LED being turned on.
4. If the generator starts but shuts down after a few seconds due to a fuel problem, etc. The GSCM-mini goes thru its shutdown routine then re-enters ready mode after a 60 second delay. During this delay the start LED will blink rapidly. The GSCM-mini will then try to start the generator again in manual mode or after a 5 minute delay period in auto-start mode.
5. When a run condition is detected, the GSCM-mini turns on the run LED and open collector transistor output (remote run lamp) and after a 60 second generator stabilization period begins monitoring the AC Hz signal for over/under Hz condition.
6. If the generator starts but shuts down after the 60 seconds stabilization period, due to a fuel problem, low oil pressure, broken AC Hz or 12V run pilot light status wire, the GSCM-mini blinks the generator Hz LED for an under Hz condition, after 60 seconds the run LED turns off, K2 relay energizes for 5 seconds, and fault LED turns on and the generator Hz LED blinks four times every two seconds. The GSCM-mini enters a fault shutdown lockout condition and must be powered down to reset the fault lockout.
7. If no faults occur, the generator continues running until one of the following occurs: The manual start signal is no longer received, the auto battery charge voltage or max run time has been reached while running in auto charge mode, an over or under Hz condition occurs if generator Hz shutdown is enabled or the generator runs out of fuel.
8. Shutdown routine, K1 de-energizes, then ½ second later K2 relay energizes, remains closed until the AC Hz signal from the generator goes to zero for 5 seconds ensuring generator shutdown.
9. The generator remains off until another start signal is received.



The configuration terminal 6 has been connected to B+ (terminal 3), configuring the GSCM-mini-o for ignition/crank start sequence. The GSCM-mini is then powered by connecting B+ (+12 VDC) to terminal 2. The start LED turns on for 5 seconds while the GSCM-mini initializes with option #3 ignition/crank starting sequence then begins blinking the start LED once every 5 seconds. The generator starting sequence is as follows:

1. The start LED blinks once every 5 seconds to indicate that the GSCM-mini is in a ready mode. When a manual signal is received, the start LED lights continuously. After a 2 second delay, K2 relay energizes and remains energized until the start signal is either removed or the generator fails to start after 3 attempts. K1 relay closes to crank the starter. The K1 relay remains closed until either the generator starts or the maximum cranking time period (30 seconds) is reached.
2. If the generator fails to start after the 30 seconds cranking period, K1 relay opens for a resting period of 40 seconds. The K1 relay then closes again cranking the starter until the maximum cranking time is reached or the generator starts.
3. If the generator fails to start after 3 cranking attempts with the associated resting periods then K2 relay de-energizes and enters its shutdown routine, then the generator Hz LED does a double blink, the fault LED turns ON and the GSCM-mini enters the maximum crank lockout condition. This lockout condition remains until the GSCM-mini is reset by removing power from terminal 2 (see GSCM-mini wiring diagram page 4) and reconnecting power. The GSCM-mini will then clear the lockout condition, and enter ready mode with the start LED blinking every 5 seconds.
4. When the generator starts, K1 relay immediately opens, stopping the cranking. A valid run condition is determined by one of two conditions: A 12V run pilot light signal provided by the generator connected to terminal 8, or by the generator's AC output frequency exceeding the crank disconnect setting of 45Hz (terminals 9 & 10) and is indicated by the run LED being turned ON.
5. If the generator starts but shuts down after a few seconds due to a fuel problem, etc., the start sequence will revert to the ready mode after a 60 second delay. During this delay the start LED will blink rapidly. The GSCM-mini will then try to start the generator again in manual mode or after a 10 minute delay period in auto-start mode.
6. When a run condition is detected, the GSCM-mini turns ON the run LED and open collector transistor output (remote run lamp) and after a 60 second generator stabilization period begins monitoring the AC Hz signal for over/under Hz condition.
7. If the generator starts but shuts down after the 60 seconds stabilization period, due to a fuel problem, low oil pressure, broken AC Hz or 12V run status wire, the GSCM-mini blinks the generator Hz LED for an under Hz condition, after 60 seconds the run LED turns off, K2 relay energizes for 5 seconds, and fault LED turns on and the generator Hz LED blinks four times every two seconds. The GSCM-mini enters a fault shutdown lockout condition and must be powered down to reset the fault lockout.
8. The generator continues running until one of the following occurs: The manual start signal is no longer received, the auto battery charge voltage or max run time has been reached while running in auto charge mode, an over or under Hz condition occurs (if generator Hz shutdown is enabled) or the generator runs out of fuel.

When the manual start signal is removed, K2 relay de-energizes opening the ignition circuit shutting down the generator. The GSCM-mini then monitors the generator AC Hz input to watch for a zero Hz condition before returning to ready mode. If the AC signal remains the GSCM-mini's generator HZ LED turns on indicating AC Hz. Signal still present and will not return to ready mode until the AC signal goes to zero. Once it goes to zero the GSCM-mini returns to ready mode.



The manual start signal is created by connecting terminal 5 (manual start) to terminal 3 (B+12VDC) through a power/reset switch. It may also be generated by an Outback Inverter using the AUX+/- connections on the remote terminal block. The Outback provides a switched +12VDC signal for the GSCM-mini-o's manual start input. An optional manual-off-auto switch can be installed to provide user flexibility for manual starts, resets, turning the unit off, or auto starting from inverter. See GSCM-mini-o wiring diagram, upper right hand corner.

The GSCM-mini-o detects five fault shutdown conditions, they are as follows:

1. Failure to start with 3 cranking attempts (see Relay Options-1:3, 2:2, & 3:3). The generator Hz shutdown LED does a double blink and fault LED on continuously.
2. High frequency (over Hz) condition. If the generator AC output is connected to terminals 9 and 10 and the generator Hz enable terminal 8 is grounded, the GSCM-mini monitors the generator's output frequency and if it exceeds the 65 Hz fixed threshold for 10 seconds, the generator shuts down and the generator Hz shutdown LED blinks rapidly. The generator Hz LED blinks during this 10 second period.
3. Low frequency (under Hz.) condition. If the generator AC output is connected to terminals 9 and 10 and the generator Hz enable terminal 8 is grounded, the GSCM-mini monitors the generator's output frequency and if it drops below the 55 Hz fixed threshold for 10 seconds, the generator shuts down and the generator Hz shutdown LED blinks slowly. The generator Hz LED blinks during this 10 second period.
4. Auto Start within 30 minutes of max run time shutdown (see Automatic Starting for Battery Charging line 4). The generator Hz shutdown LED does a triple blink and fault LED on continuously.
5. Generator shuts down on its own fault. While the GSCM-mini is in run mode, and the generator is running, if the generator shuts down on a fault condition (low oil pressure, hi temperature, or out of fuel) or the AC Hz signal fuse or wire opens or the 12V run status wire opens, the GSCM-mini goes thru its shutdown routine and enters a fault condition, turning on the red fault LED and blinking the generator Hz LED four times every two seconds.

The over/under Hz detection not enabled until the generator has been running for 60 seconds and will shut down the generator after 10 continuous seconds of Hz fault condition, locking it out until a power down reset and power back up. The fault open collector transistor output (terminal 12) will energize a user supplied remote lamp or DC relay (not exceeding 300 milliamp coil current) whenever a fault shutdown occurs and will de-energize the relay when the fault is reset.



The GSCM-mini-o can monitor either the generator battery voltage or a battery bank voltage and automatically start/stop the generator based on battery voltage. This is accomplished by connecting the battery voltage to the battery sense input (terminal 4). The GSCM-mini-o monitors a battery voltage range of 0 to 60VDC and automatically determines the start and stop set point based on battery voltage (12, 24, or 48VDC). Below 16VDC - uses 12V thresholds, between 16 to 32V -uses 24V thresholds, above 32V - uses 48V thresholds. This mode is disabled if the voltage on terminal 4 is less than 6V, (no connection).

1. The GSCM-mini monitors the battery sense input and when the battery voltage drops below the start threshold the Start LED begins blinking every second. When the battery voltage has remained below the start threshold for 5 continuous minutes the auto start sequence begins. If the battery voltage rises above the start threshold during the 5 minute period the 5 minute timing cycle starts over. (Temporary battery voltage fluctuations such as instantaneous inverter loads will not start the GSCM). The start LED blinks every 3 seconds while the GSCM-mini is running the generator in auto-start mode.
2. The GSCM-mini starts the generator as described on page 3-1: momentary start, 2: maintained start, or 3: ignition start.
3. The GSCM-mini shuts down the generator (as described in Relay Options 1, 2, or 3) whenever the battery voltage exceeds the stop threshold for 10 minutes. The Start LED blinks (every second) during this 10 minute period. The GSCM-mini will exit the 10 minute period and shutdown the generator if the battery voltage exceeds the stop threshold by +1.0V for a 12V system, 2V for 24V system and 4V for a 48V system. The generator remains off until the battery voltage drops below the start threshold voltage.
4. The GSCM-mini will shut down the generator when it has run in auto-start battery charging mode for 6 hours and has not charged the battery above the shutdown threshold. The GSCM-mini then returns to ready mode looking for a start command. If the battery voltage drops below the Auto start threshold within 30 minutes of a max run time shut down the GSCM-mini will enter a max run time fault condition and lock out the start sequence and requires a power down reset. The generator Hz LED will blink 3 quick blinks every 5 seconds and the fault LED is on continuously.
5. If the user wishes to manual-start the generator from a separate pressure switch, level switch, thermostat or inverter start contact, etc., the battery voltage is fed through the switch (pressure switch etc.) contact to Manual start terminal 5. Closing the contact will cause the GSCM-mini to start the generator. Some inverters provide a switch 12VDC signal to start the generator. This switched voltage can be connected directly to the manual start terminal 5 and ground terminal 7.

The GSCM-mini-o Generator Start Stop module is **NOT AN EMERGENCY SHUTDOWN DEVICE!** If the manual start signal is removed the generator will go through a normal shutdown which may take up to 15 seconds to completely shut down the generator.

A RECOMMENDED EMERGENCY SHUTDOWN SOLUTION is to install a separate "Kill" switch and label it as such. The recommended wiring is shown on page-4 of these instructions and also in Option 1. Disconnecting the power to the GSCM-mini module will force the relays to open. This will shut down generators that require a maintained run signal from K1 relay. However this also prevents the K2 relay from closing to shut down those generators requiring a momentary stop signal. Using a double pole "Kill" switch and wiring the second pole in parallel with the K2 relay terminals will force the generator to stop in an emergency situation such as a fuel spill. (See note 1 on wiring diagram, page 4, for Ignition/crank emergency shutdown option).



LED Description and Meanings

Start:	One blink every 5 seconds = ready mode, looking for a start signal One blink every 2.5 seconds = auto start mode operation One blink every other second= auto start/stop period Continuous = manual start signal received Fast blink = 60 second delay after start signal removed before generator started
Generator Hz Shutdown:	Fast blink = over speed condition Slow blink = under speed condition Double blink = maximum crank attempts reached, failed to start Triple blink = auto start attempted with-in 30 minutes of a max run time (6 hour) shutdown Four blinks every 2 seconds = AC Hz or 12V run status signal lost during run mode Continuous = start function disabled, AC Hz detected while in ready mode
Run:	Continuous = GSCM-mini has a valid run signal from generator
Fault:	Continuous = GSCM-mini is in a fault condition and requires a reset
K1 & K2:	Continuous = status of K1 and K2 relays on

Specifications

Size:	5.13" L x 2.853" W x 1.35" H	Gen. Hz Enable: (Terminal 8)	Open input = Generator Hz shutdown not active
Weight:	20oz.		Grounded input = Generator Hz shutdown active
Mounting:	2 screws through tabs		12VDC input = Generator run Status input
Power:	12VDC Battery 9.5 to 15VDC Quiescent current < 10mA Relay current < 25mA each		Over/under Hz shutdown not active
Manual Input:	B+ (12VDC) input = on condition Open input = off condition	Frequency Input: (Terminals 9 & 10)	24VAC, 120VAC & 240VAC 0-100 Hz
Battery Input:	0-60VDC	Output Ratings:	Two 10 AMP 28VDC relay contacts, K1 has 38VDC MOV across contact. Two open collector NPN transistors, maxium 300mA each
Auto Start/ Stop Threshold:	12V System 11.5V, 13.8V 24V System 23.0V, 27.6V 48V System 46.0V, 55.2V	Fault Detection:	Start failure, (3 attempts) Over Hz condition (10 seconds) Under Hz condition (10 seconds) Max run time (6 hours) Loss of AC Hz or 12V run status signal
Relay Configuration: (Terminal 6)	Open input = momentary crank Grounded input = maintained crank B+ (12VDC) input = ignition & crank		
Ambient Temp:	-40 to 85°C		



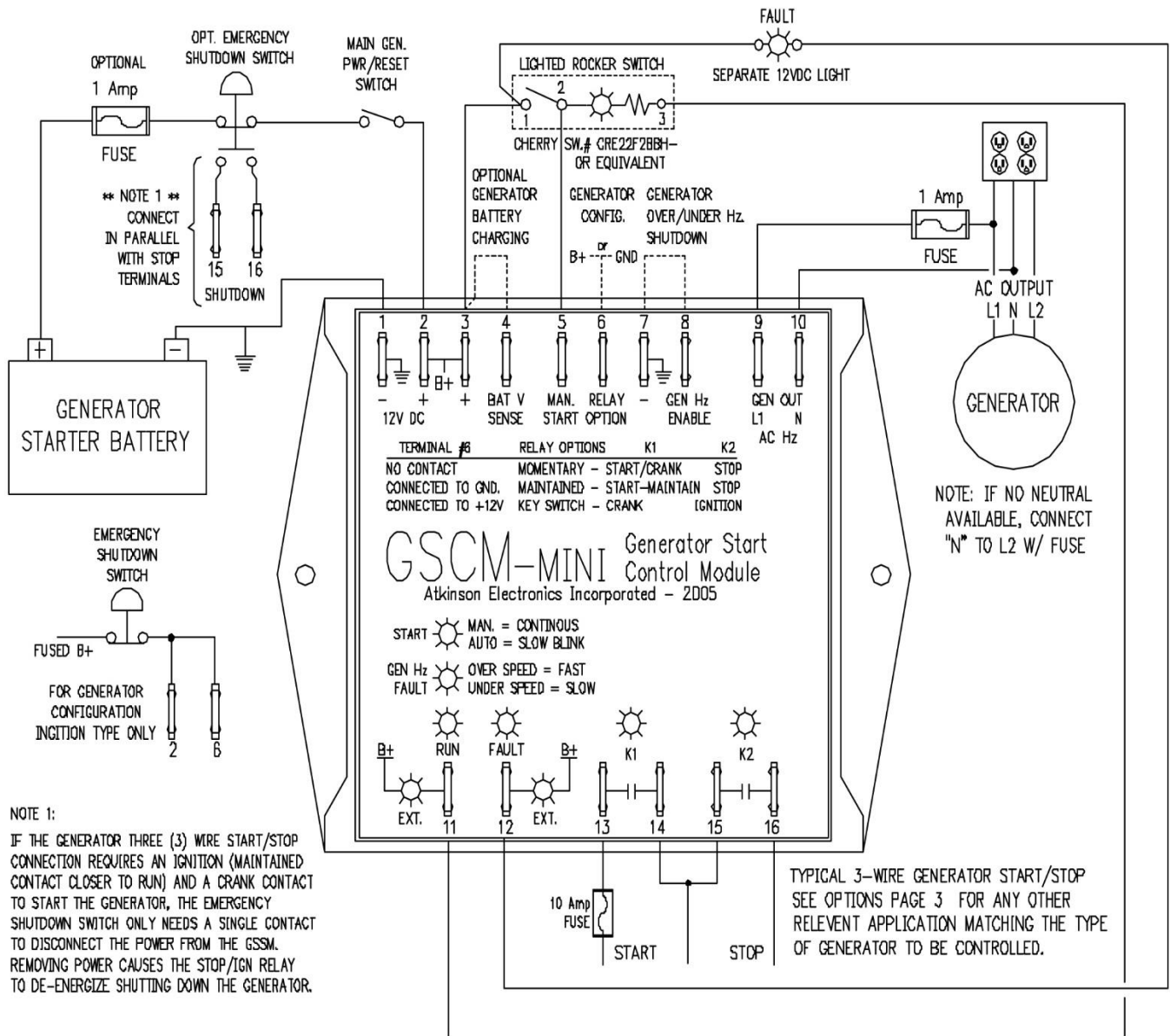

The GSCM-mini-o can be used to replace a typical remote generator control console that is mounted on the dash of a motorhome. Instead of a large console and cable, use a small 16 to 18 gauge 4 wire signal cable, an on-off switch with built in lamp and a separate 12VDC fault lamp. When the remote switch is turned on, the GSCM-mini starts the generator. After the generator starts and comes up to speed the run LED lights on the GSCM-mini and turns on the remote start switch lamp. If the generator fails to start or fails while commanded to run the fault LED on the GSCM-mini lights along with the remote fault 12VDC lamp. Turning off the power to the GSCM-mini resets the fault condition and it is ready to receive another start command. See page 5 for a typical 3 or 4 wire generator hookup. Check your owner’s manual for the electrical diagram to know if the GSCM-mini (3 or 4 wire) 2 relay contact start/stop will work with your generator.



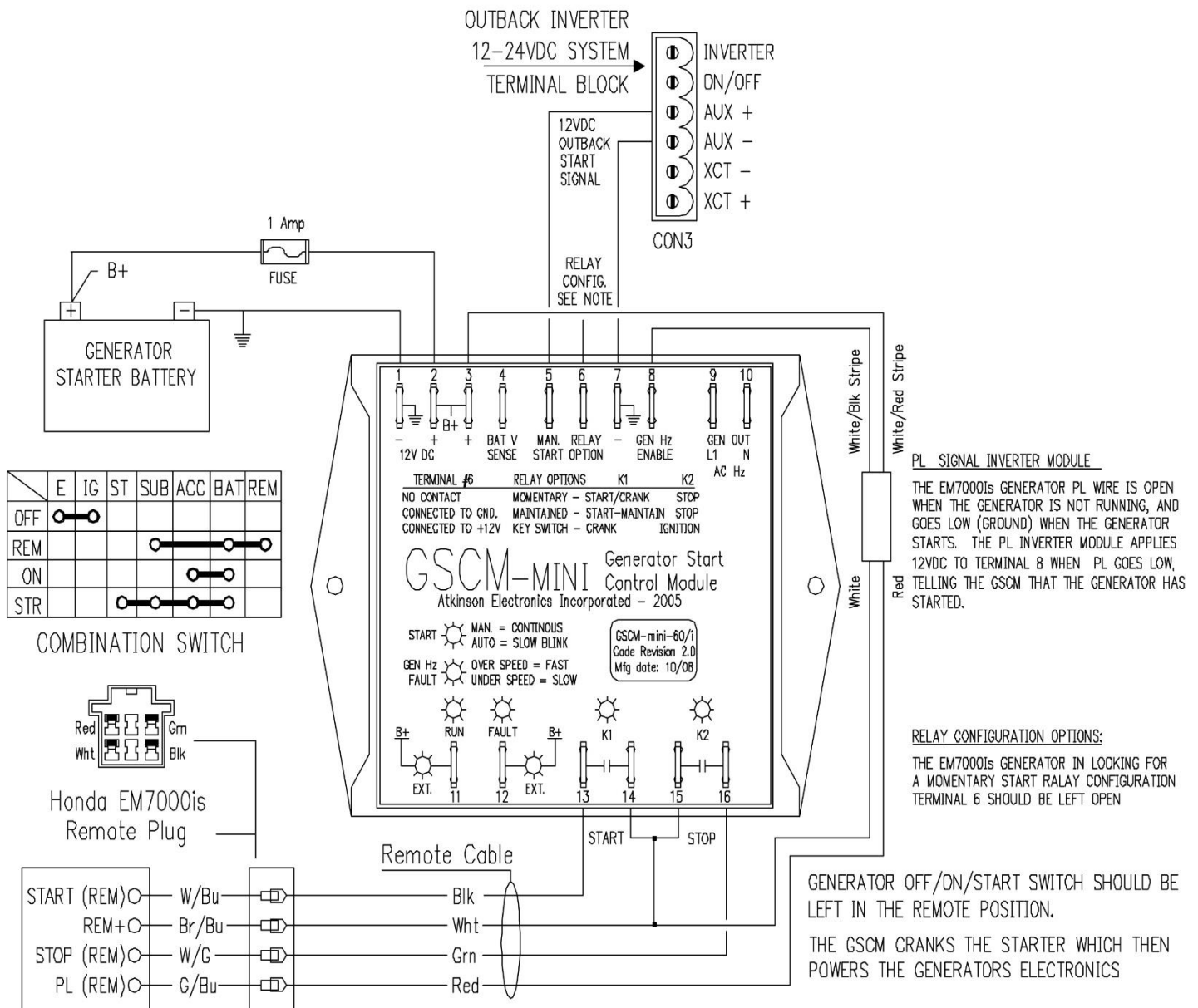

The GSCM-mini-o accepts Outback is a two wire (switched 12VDC) generator start/run signal to a 3 or 4 wire start/stop signal for most gas and propane generators. Onan & Honda Inverter style generators do not produce an AC output until the generator is up to speed, thus the standard AC connection on the GSCM-mini is not used. By using the generator's remote control plug connections to connect the GSCM-mini's start and stop contacts, and the remote pilot lamp signal, the pilot lamp signal tells the GSCM-mini when to disengage the starter when starting and when the generator has stopped when shutting down. A red connector with a protection diode is provided with the GSCM-mini-i or sold separately (A0396). It connects between terminal 8 on the GSCM-mini and pilot lamp signal wire (see page 15). The pilot lamp's signal must go high when the generator starts when referenced to the battery negative (ground). If pilot lamp goes low see above for an example. The generator's combination switch should be placed in the remote position for the GSCM-mini to be able to auto start the generator.

Outback Inverter and Honda's EUxx00is Inverter Output Generators Example

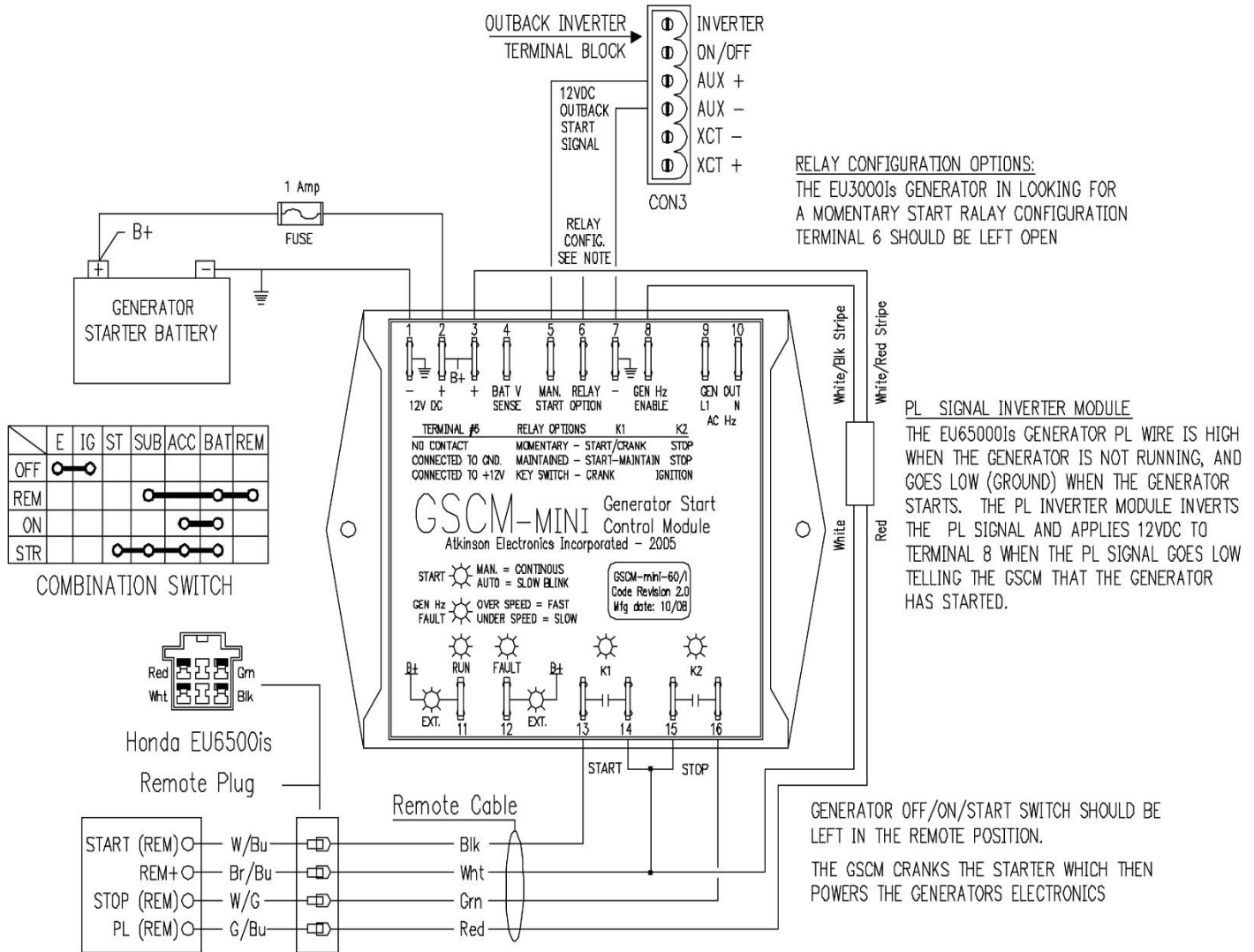

The GSCM-mini-o accepts Outback's two wire (switched 12VDC) generator start/run signal to a 3 or 4 wire start/stop signal for most gas/ propane generators. **The newer Honda inverter output style generators (EU5000is, EU6500is, & EU7000is) do not produce an AC output until the generator is up to speed, thus the standard AC connection on the GSCM-mini is not used. By using the generators remote control plug connections to connect the GSCM-mini's start and stop contacts, and the remote pilot lamp signal, the pilot lamp signal tells the GSCM-mini when to disengage the starter when starting and when the generator has stopped when shutting down.**

Honda generators use a positive reference (B+) for their control and the pilot lamp signal goes low to turn on the lamp. A pilot lamp signal inverter module is supplied with the GSCM-mini-i or purchase separately (A0396). It inverts the pilot lamp signal logic and tells the GSCM-mini when the generator has started and to disengage the starter. The white with red stripe connects to terminal 3 and white with black stripe wire connect to terminal 8 on the GSCM-mini. The red and white wires connect to the red and white wires in the Honda remote control wiring harness or the green/blue wire in the remote plug. The generator's combination switch should be placed in the remote position for the GSCM to be able to auto start the generator.

Please note that there are many various generators, each with their own wiring diagram. If you have any questions please contact cbdsales@atkinsonel.com for the proper hookup diagram. Please include the generator make & model, inverter brand, & battery bank voltage.



Samlex America Inverter and Honda's EU3000s Inverter Output Generator Example

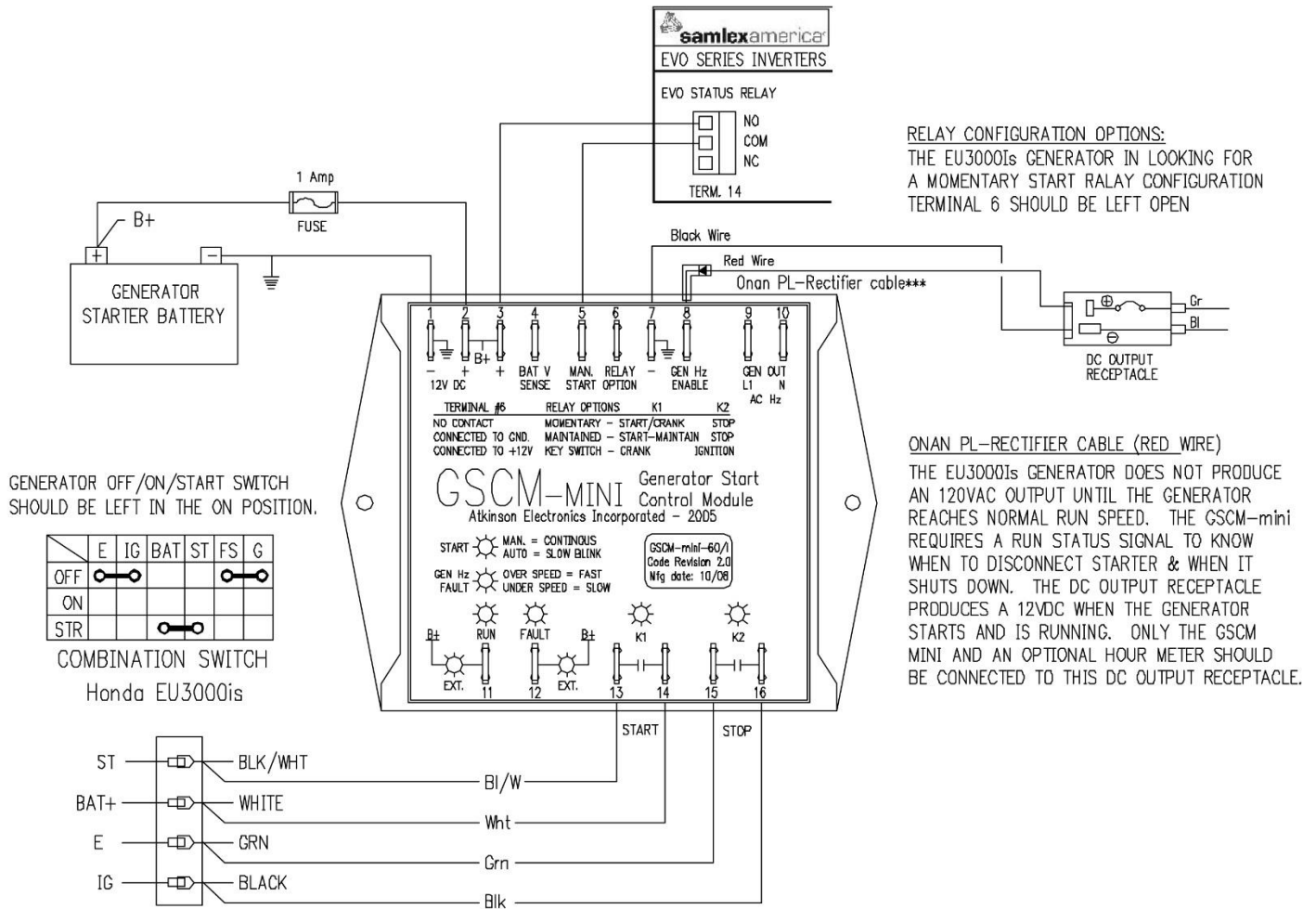

The GSCM-mini-o can be used with Outback invertors and most 3 or 4 wire gas generators. Outback's 2 wire start/run output is a switched 12VDC signal, the GSCM-mini was designed to accept the switched 12VDC start signals from the Outback Inverter and provide two relay contact outputs that can be wired as 3 or 4 wire start/ stop configurations (see page 4 for generator wiring configurations examples). The GSCM-mini monitors the generator's AC output to know when to disengage the starter, if an over/under Hz condition has accrued (optional, terminal 8 is grounded), and when the generator has shutdown, either by command or by fault. An optional manual on/off-auto switch can be used to manually turn on or off the generator, or run automatically from the inverter (see above drawing example). When a start signal is received the GSCM-mini starts the generator, after the generator starts and comes up to speed the run LED lights on the mini. If the generator fails to start after 3 starting attempts or fails while commanded to run, the fault LED on the GSCM mini lights and the generator Hz fault LED blinks to indicate the type of failure.

Turning off the power to the GSCM-mini either by emergency shutdown switch or an optional power on/off switch, for 5 seconds and then back on, resets the fault condition and the GSCM-mini is ready to receive another start command.



Atkinson Electronics, Inc. gives this express warranty (along with extended warranty endorsements, where applicable) in lieu of all other warranties, express or implied, including (without limitation), warranties of merchantability and fitness for a particular purpose. This constitutes Atkinson Electronics, Inc.'s sole warranty and obligation with regard to our products as well as the Customer's sole remedy.

Atkinson Electronics, Inc. expressly disclaims all liability and responsibility for any special, indirect or consequential damages or any further loss of any kind whatsoever resulting from the use of our product. The Customer's sole and exclusive remedy and the limit of Atkinson Electronics, Inc.'s liability for any loss whatsoever, shall not exceed the purchase price paid by the Customer for the product to which a claim is made.

Countries or States that do not allow limitations of incidental or consequential damages or on how long an implied warranty lasts, the above limitations may not apply to you. This warranty gives you specific legal rights and you may also have other rights which vary from State to State or Country to Country.

All products manufactured by Atkinson Electronics, Inc. are warranted to be free from defects in material and workmanship in accordance with and subject to the following terms and conditions:

1. This warranty is limited to the original customer only. It cannot be transferred or assigned to third parties unless the intent to transfer to a third party is expressly indicated in a purchase order and/or warranty processing arrangements have been agreed upon in writing by Atkinson Electronics, Inc.
2. Atkinson Electronics, Inc. will correct any defects in material or workmanship which appear within two (2) years from the date of shipment by Atkinson Electronics, Inc. (or its authorized distributors) to the original Customer. Atkinson Electronics, Inc. will repair or replace, at our option, any defective products, provided that our inspection discloses that such defects developed under normal and proper use. This warranty does not extend to goods subjected to misuse, neglect, accident or improper installation, or to maintenance or repair of products which have been altered or repaired by anyone except Atkinson Electronics, Inc., unless otherwise stated in writing. Atkinson Electronics, Inc. will correct any defects in material or workmanship of OEM products (designated as such in our catalog or web site) which appear within two (2) years from the product date code or from the factory invoice date, whichever is later.
3. An appropriate charge (25% of product list price) may be made for testing, repairs, replacement and shipping for a returned product which is not defective or found to be defective as the result of improper use, maintenance or neglect.
4. Atkinson Electronics, Inc. will not accept responsibility for any invoiced goods or services that are not covered by an Atkinson Electronics, Inc. written purchase order. Under no circumstances does Atkinson Electronics, Inc. agree to pay for labor or other related expenses associated with the troubleshooting and/or repair of our product without prior specific written authorization.
5. Information in our descriptive literature is based on product specifications that are current at the time of publication.

Product specifications, design and descriptive literature are subject to change as improvements are introduced. Although we announce changes as they occur, we cannot guarantee notification to every Customer. Atkinson Electronics, Inc. warrants delivered products to conform to the most current specifications, design and descriptive literature. This warranty policy may be expanded or limited, for particular categories of products or customers, by information sheets published as deemed appropriate by Atkinson Electronics, Inc.

